



WINCHESTER  
COLLEGE

## Entrance Examination Geography

Wednesday 2<sup>nd</sup> May 2018

Total time allowed: 1 hour

Candidates are allowed an extra ten minutes at the start of the examination to read the paper.

### SECTION A

**All candidates MUST answer this section**

Candidates should answer all the questions in this section on the separate resource sheet.

### SECTION B

Candidates must choose **three** of the four questions.

All questions are worth equal marks.

Please start each question on a new sheet of paper.

Credit will be given for relevant diagrams used in the answers.



## SECTION B

Answer three questions from this section.

### QUESTION 1: TECTONIC PROCESSES

Fig 1: A diagram showing the structure of the Earth.

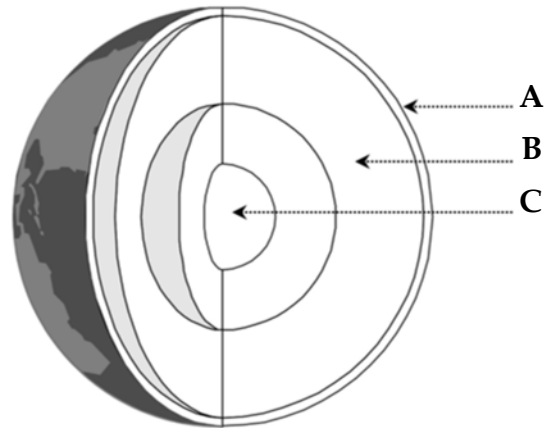
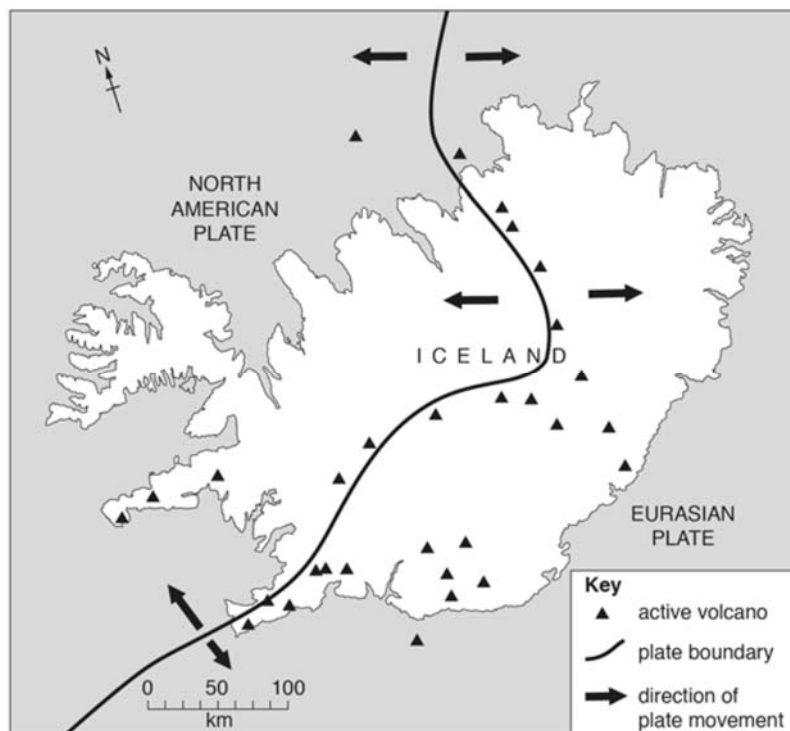

Fig 2: A diagram showing the distribution of volcanoes in Iceland



- Name the layers of the Earth A, B and C shown in Fig 1. (3)
- What type of plate boundary is shown in Fig 2? (1)
- Explain why there are active volcanoes in Iceland (3)
- Describe the distribution of volcanoes in the world (4)
- Describe the primary hazards and secondary impacts of a volcano you have studied (9)

(Total = 20 marks)

**QUESTION 2: COASTS**

**Fig 3: Sea-level rise since 1880**

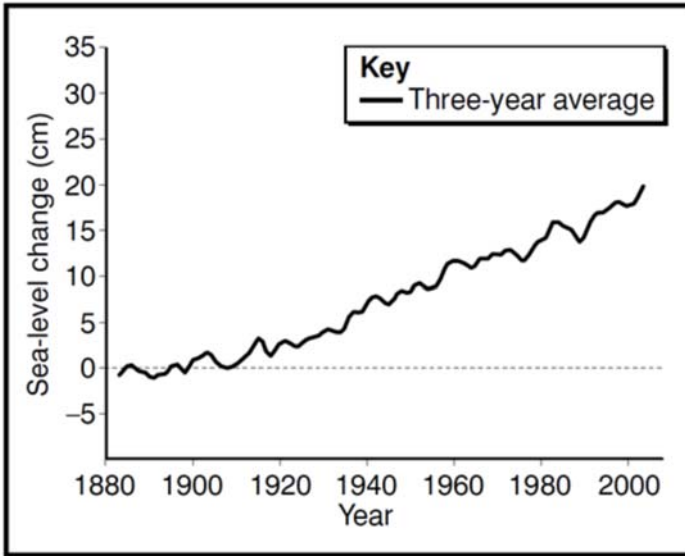

**Fig 4: Some scientific agencies' predictions for sea-level rise over the next 90 years.**

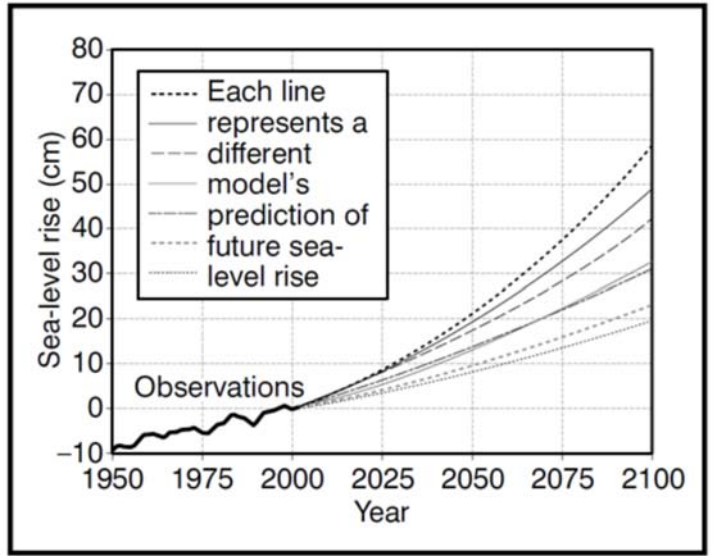

- a) Describe the trend shown in Fig 3. (2)
- b) What do you think is causing the trend shown in Figs 3 and 4? (1)
- c) How do you think the trend shown in Fig 3 and 4 will affect coastal environments? (2)
- d) What can be done to reduce the impacts of sea level rise along a coastline? (4)
- e) What is meant by marine erosion? (2)
- f) Explain what is meant by the term attrition. (2)
- g) Explain how different erosional processes shape cliffs and develop landforms. You may use diagrams with your answer. (7)

(Total = 20 marks)

**QUESTION 3: POPULATION AND SETTLEMENT**

**Fig 5: Population changes in three countries.**

Country	Birth Rate	Death Rate	Natural Population Growth
Japan	7.7	9.8	-2.1
Kenya	31.8	6.7	25.1
Sweden	12.1	9.4	

Study Fig. 5, which shows information about population changes in three countries.

- a) Explain the meaning of birth rate. (2)
- b) What is meant by natural population growth? (2)
- c) Calculate the natural population growth of Sweden. You should show your calculations with your answer. (2)
- d) To work out **population change** in Sweden over a year, what extra information would you need other than that shown in Fig 5? (2)
- e) Suggest the likely difficulties which planners and city authorities face in urban areas with very high population densities. (5)
- f) Describe and explain some of the factors which early settlers considered when choosing sites for new settlements (7)

(Total = 20 marks)

## QUESTION 4: Transport and Industry

Fig 6 Nestle coffee factory in the village of Hatton, UK.



Copyright Simon Johnson

Fig 7 Coal mining, Kalgoorlie, Australia



Source Wikipedia Commons

**Study Fig 6 and Fig 7 on page 6.**

- a) Which sector of the economy is shown in Fig 6? (1)
- b) Which sector of the economy is shown in Fig 7? (1)
- c) Describe two benefits of the economic activity shown in Fig 6 for local people. (2)
- d) Suggest how the economic activity shown in Fig 7 could damage the natural environment. (3)
- e) How might the raw materials used in the factory shown in Fig 6 be transported? (1)
- f) Explain how the cost of transport influences the location of different types of industry. (4)
- g) Explain the reasons for the location of of a multi-national company or an economic activity you have studied. (8)

(Total = 20 marks)

**BLANK PAGE**